

Enhancement Mode N-Channel Power MOSFET

Features

- ◆ Low $R_{DS(on)}$ & FOM
- ◆ Extremely low switching loss
- ◆ Excellent stability and uniformity
- ◆ Easy to drive

Applications

- ◆ Lighting
- ◆ Hard switching PWM
- ◆ Server power supply
- ◆ Charger

■ General Description

OSG65R290x use advanced GreenMOSTM technology to provide low $R_{DS(ON)}$, low gate charge, fast switching and excellent avalanche characteristics. This device is suitable for active power factor correction and switching mode power supply applications.

◆ $V_{DS, min@Tjmax}$	700 V
◆ $I_{D, pulse}$	45 A
◆ $R_{DS(ON), max @ V_{GS}=10 V}$	290 mΩ
◆ Q_g	18 nC

■ Schematic and Package Information

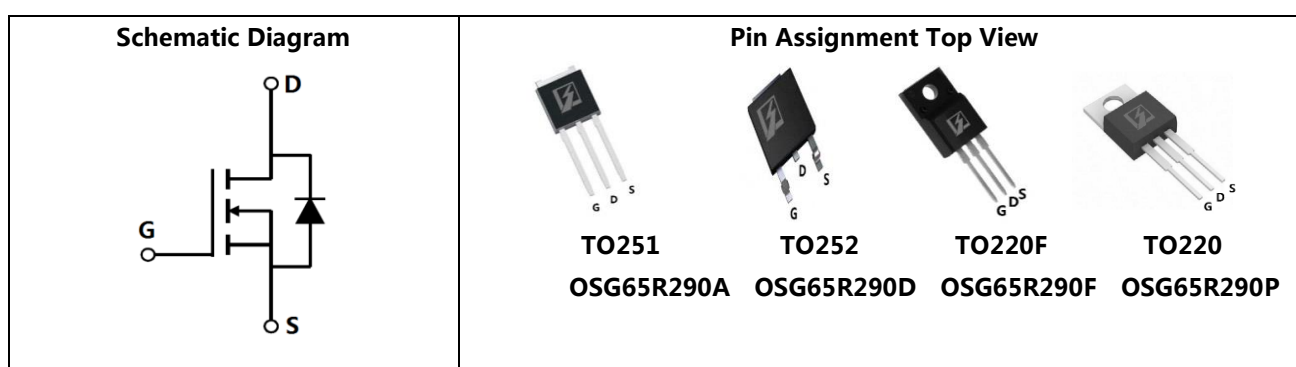

■ Absolute Maximum Ratings at $T_j=25^{\circ}C$ unless otherwise noted

Parameter	Symbol	Value	Unit
Drain source voltage	V_{DS}	650	V
Gate source voltage	V_{GS}	± 30	V
Continuous drain current ¹⁾	I_D	15	A
Continuous drain current ¹⁾ $T_j=100^{\circ}C$		9.3	
Pulsed drain current ²⁾	$I_{D, pulse}$	45	A
Power dissipation ³⁾ for TO251, TO252, TO220	P_D	104	W
Power dissipation ³⁾ for TO220F		32	
Single pulsed avalanche energy ⁵⁾	E_{AS}	400	mJ
MOSFET dv/dt ruggedness, $V_{DS}=0...480 V$	dv/dt	50	V/ns
Reverse diode dv/dt, $V_{DS}=0...480 V, I_{SD} \leq I_D$	dv/dt	15	V/ns
Operation and storage temperature	T_{stg}, T_j	-55 to 150	$^{\circ}C$

■ Thermal Characteristics

Parameter	Symbol	Value		Unit
		TO251/TO252/TO220	TO220F	
Thermal resistance, junction-case	$R_{\theta JC}$	1.2	3.9	°C/W
Thermal resistance, junction-ambient ⁴⁾	$R_{\theta JA}$	62.5	62	°C/W

■ Electrical Characteristics at $T_j=25\text{ }^\circ\text{C}$ unless otherwise specified

Parameter	Symbol	Min.	Typ.	Max.	Unit	Test condition
Drain-source breakdown voltage	BV_{DSS}	650			V	$V_{GS}=0\text{ V}$, $I_D=250\text{ }\mu\text{A}$
		700	770			$V_{GS}=0\text{ V}$, $I_D=250\text{ }\mu\text{A}$ $T_j=150\text{ }^\circ\text{C}$
Gate threshold voltage	$V_{GS(th)}$	2.0		4.0	V	$V_{DS}=V_{GS}$, $I_D=250\text{ }\mu\text{A}$
Drain-source on-state resistance	$R_{DS(on)}$		0.26	0.29	Ω	$V_{GS}=10\text{ V}$, $I_D=7.5\text{ A}$
			0.58			$V_{GS}=10\text{ V}$, $I_D=7.5\text{ A}$, $T_j=150\text{ }^\circ\text{C}$
Gate-source leakage current	I_{GSS}			100	nA	$V_{GS}=30\text{ V}$
				-100		$V_{GS}=-30\text{ V}$
Drain-source leakage current	I_{DSS}			1	μA	$V_{DS}=650\text{ V}$, $V_{GS}=0\text{ V}$

■ Dynamic Characteristics

Parameter	Symbol	Min.	Typ.	Max.	Unit	Test condition
Input capacitance	C_{iss}		986		pF	$V_{GS}=0\text{ V}$, $V_{DS}=50\text{ V}$, $f=1\text{ MHz}$
Output capacitance	C_{oss}		67.7		pF	
Reverse transfer capacitance	C_{rss}		3.36		pF	
Turn-on delay time	$t_{d(on)}$		30.9		ns	$V_{GS}=10\text{ V}$, $V_{DS}=520\text{ V}$, $R_G=25\text{ }\Omega$, $I_D=15\text{ A}$
Rise time	t_r		39.9		ns	
Turn-off delay time	$t_{d(off)}$		44.1		ns	
Fall time	t_f		49.7		ns	

■ Gate Charge Characteristics

Parameter	Symbol	Min.	Typ.	Max.	Unit	Test condition
Total gate charge	Q_g		18		nC	$I_D=15\text{ A}$, $V_{DS}=520\text{ V}$, $V_{GS}=10\text{ V}$
Gate-source charge	Q_{gs}		5.9		nC	
Gate-drain charge	Q_{gd}		6		nC	
Gate plateau voltage	V_{plateau}		5.6		V	

■ Body Diode Characteristics

Parameter	Symbol	Min.	Typ.	Max.	Unit	Test condition
Diode forward current	I_S			15	A	$V_{GS} < V_{th}$
Pulsed source current	I_{SP}			45		
Diode forward voltage	V_{SD}			1.4	V	$I_S=15\text{ A}$, $V_{GS}=0\text{ V}$
Reverse recovery time	t_{rr}		352.9		ns	$V_R=400\text{ V}$, $I_S=15\text{ A}$, $di/dt=100\text{ A}/\mu\text{s}$
Reverse recovery charge	Q_{rr}		4.4		μC	
Peak reverse recovery current	I_{rrm}		23.1		A	

■ Note

- 1) Calculated continuous current based on maximum allowable junction temperature.
- 2) Repetitive rating; pulse width limited by max. junction temperature.
- 3) P_d is based on max. junction temperature, using junction-case thermal resistance.
- 4) The value of $R_{\theta JA}$ is measured with the device mounted on 1 in 2 FR-4 board with 2oz. Copper, in a still air environment with $T_a=25\text{ }^\circ\text{C}$.
- 5) $V_{DD}=100\text{ V}$, $R_G=25\text{ }\Omega$, $L=20\text{ mH}$, starting $T_j=25\text{ }^\circ\text{C}$.

■ **Electrical Characteristics Diagrams**

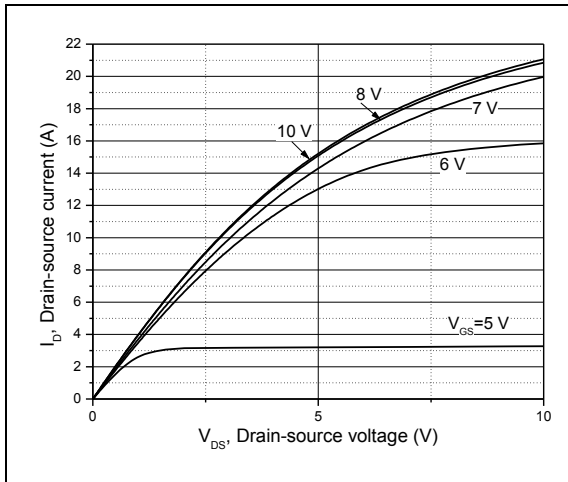

Figure 1, Typ. output characteristics

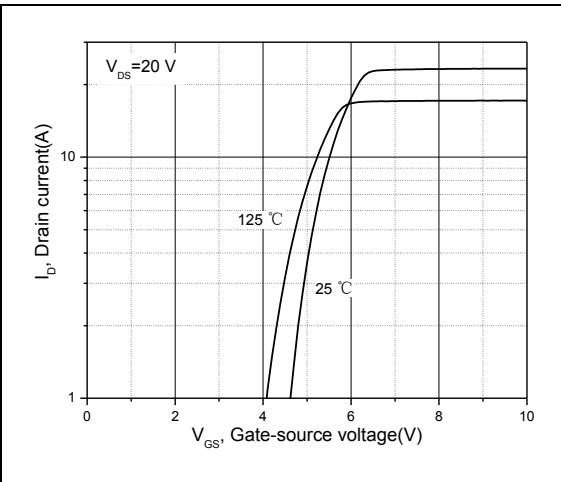

Figure 2, Typ. transfer characteristics

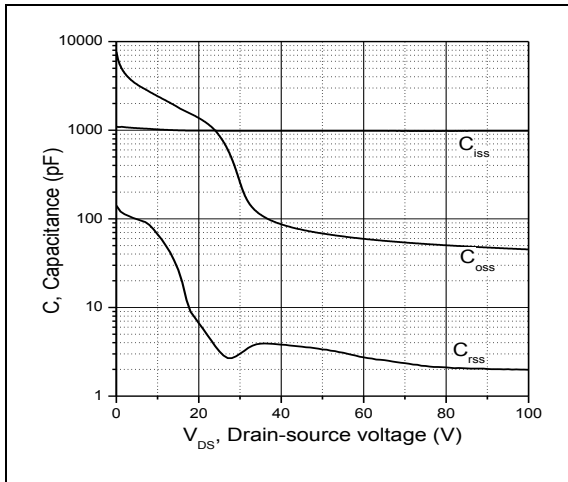

Figure 3, Typ. capacitances

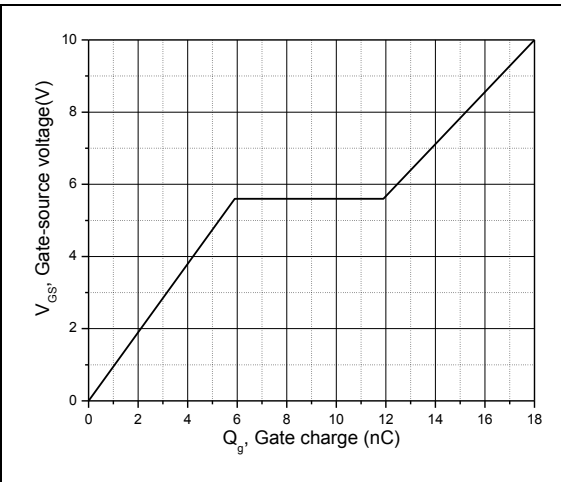

Figure 4, Typ. gate charge

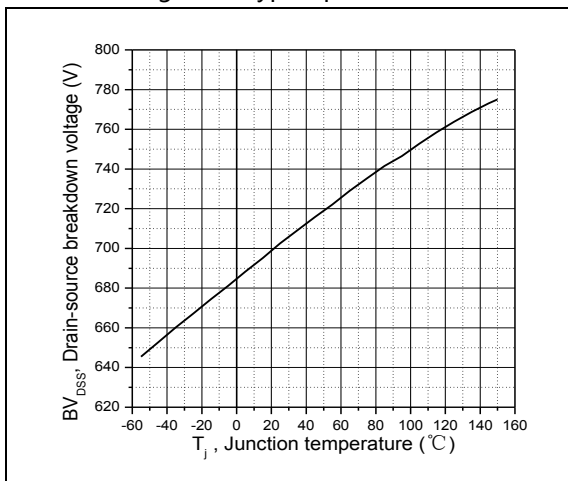

Figure 5, Drain-source breakdown voltage

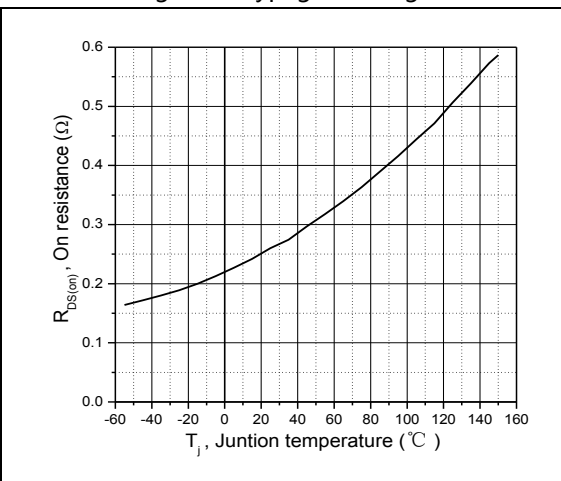

Figure 6, Drain-source on-state resistance

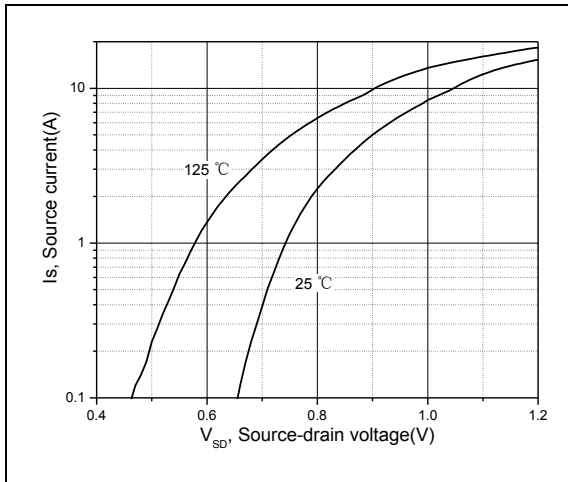

Figure 7, Forward characteristic of body diode

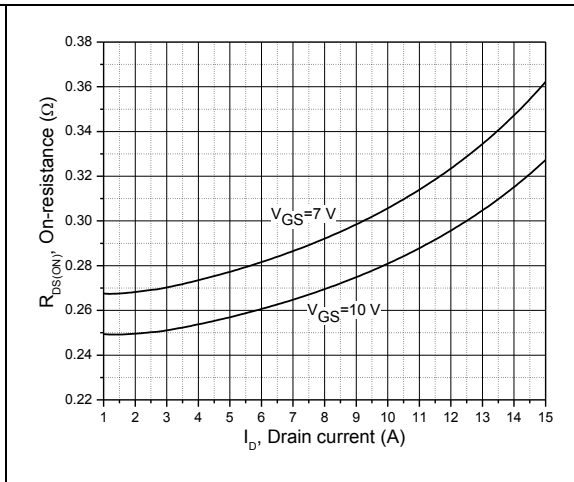

Figure 8, Drain-source on-state resistance

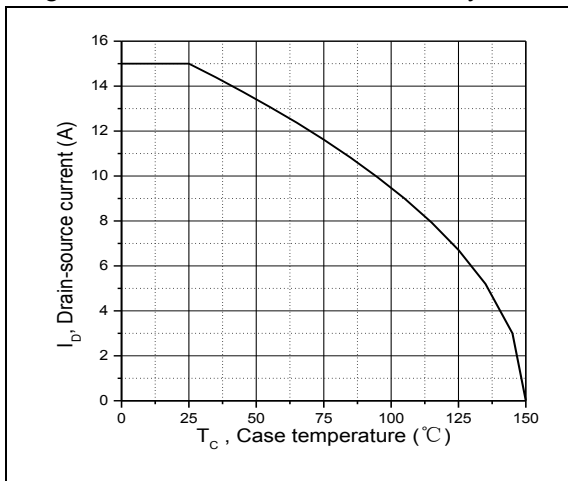

Figure 9, Drain current

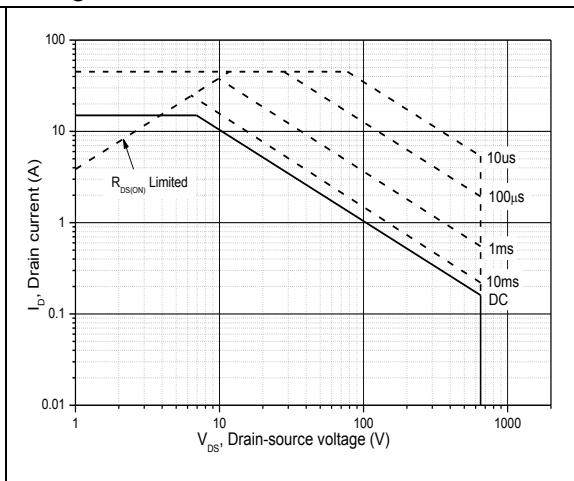

Figure 10, Safe operation area for TO251/TO252/TO220 $T_C=25\text{ }^\circ\text{C}$

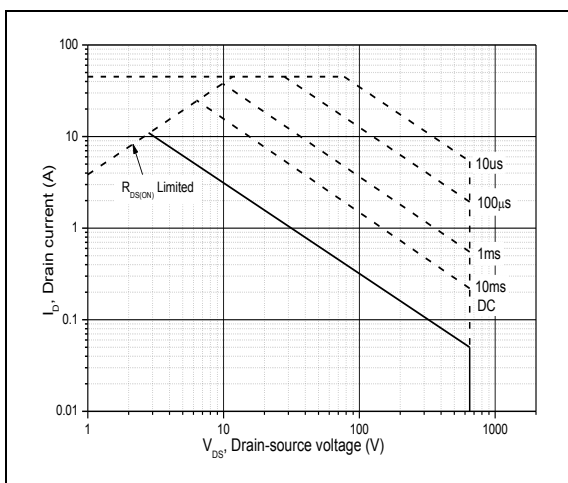

Figure 11, Safe operation area for TO220F $T_C=25\text{ }^\circ\text{C}$

■ Test circuits and waveforms

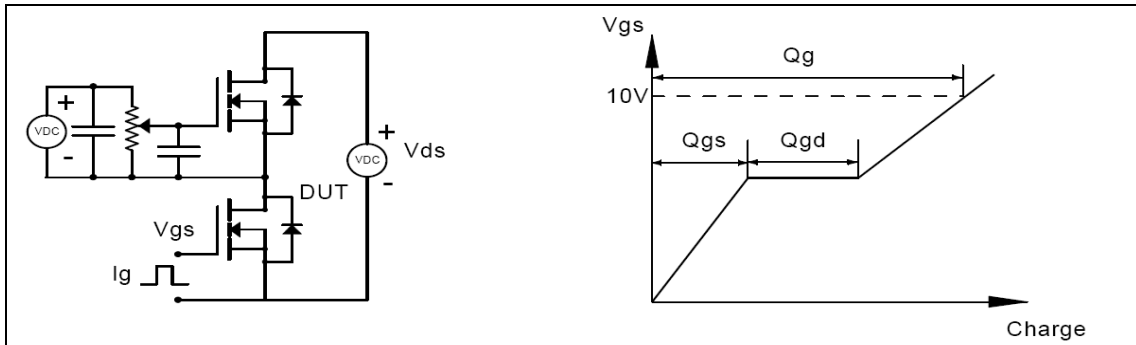

Figure 1, Gate charge test circuit & waveform

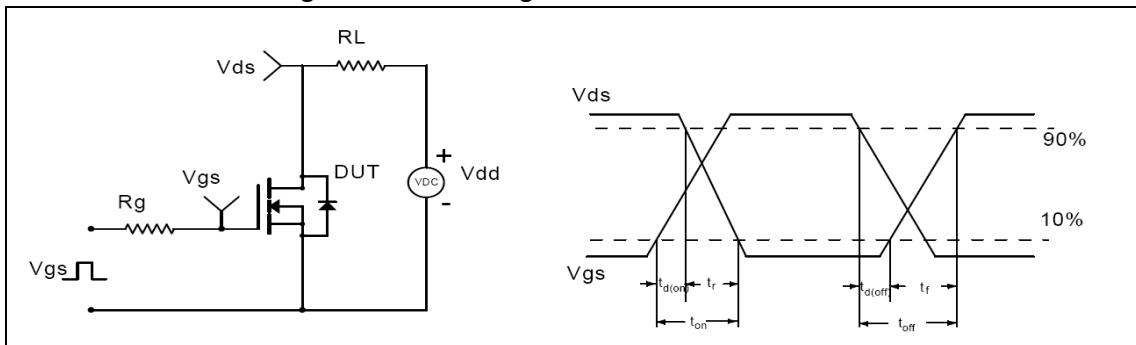

Figure 2, Switching time test circuit & waveforms

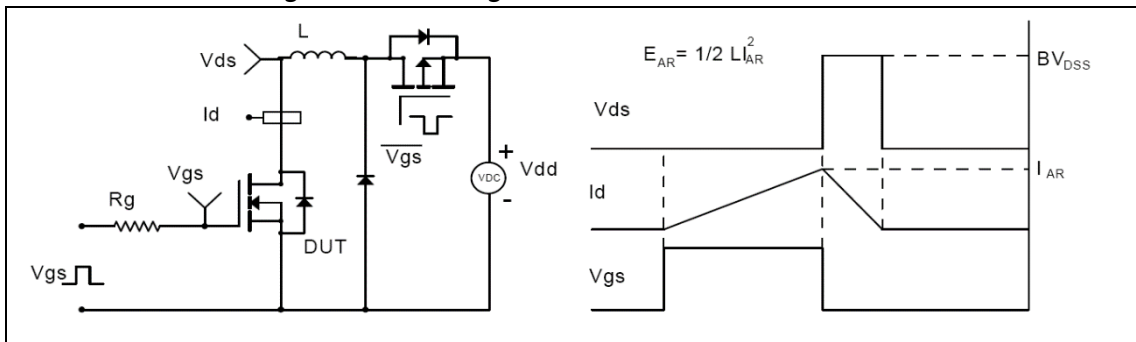

Figure 3, Unclamped inductive switching (UIS) test circuit & waveforms

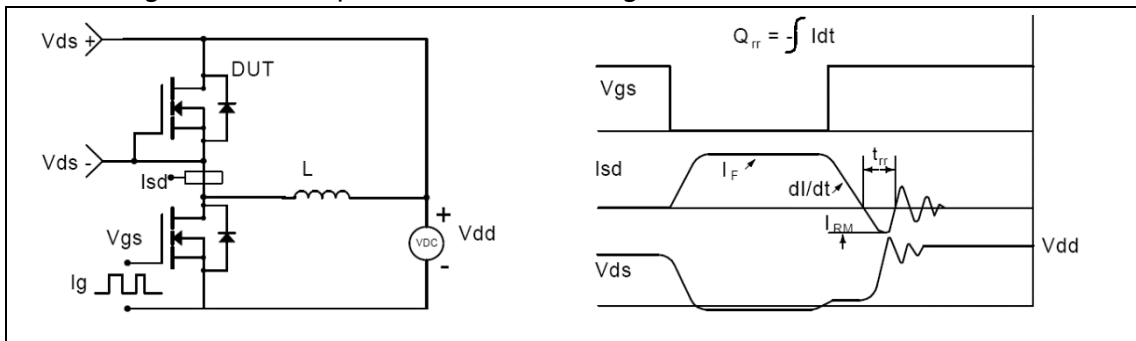
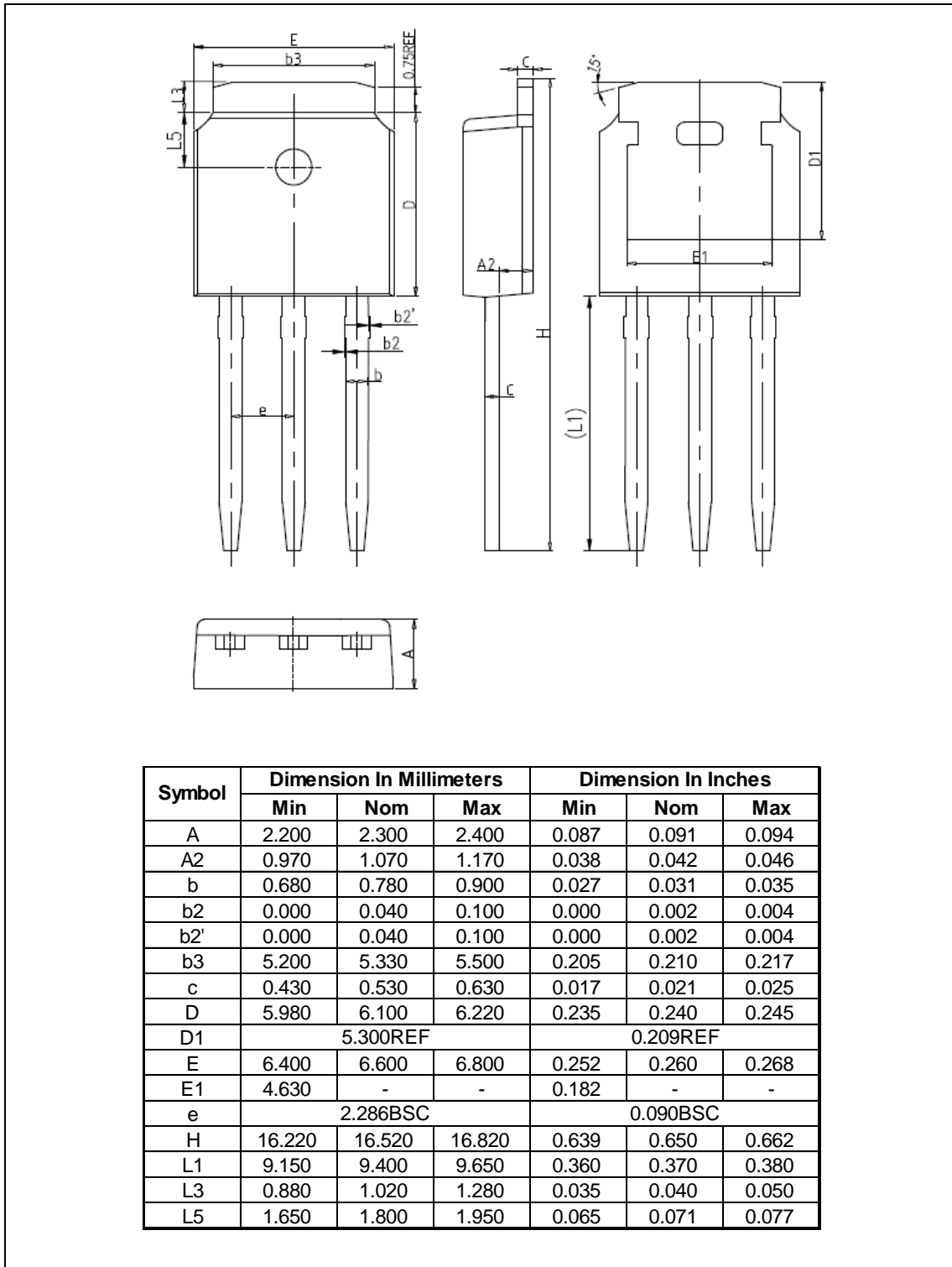

Figure 4, Diode reverse recovery test circuit & waveforms

■ Package Information

Figure1, TO251 package outline dimension



■ Package Information

Figure2, TO252 package outline dimension

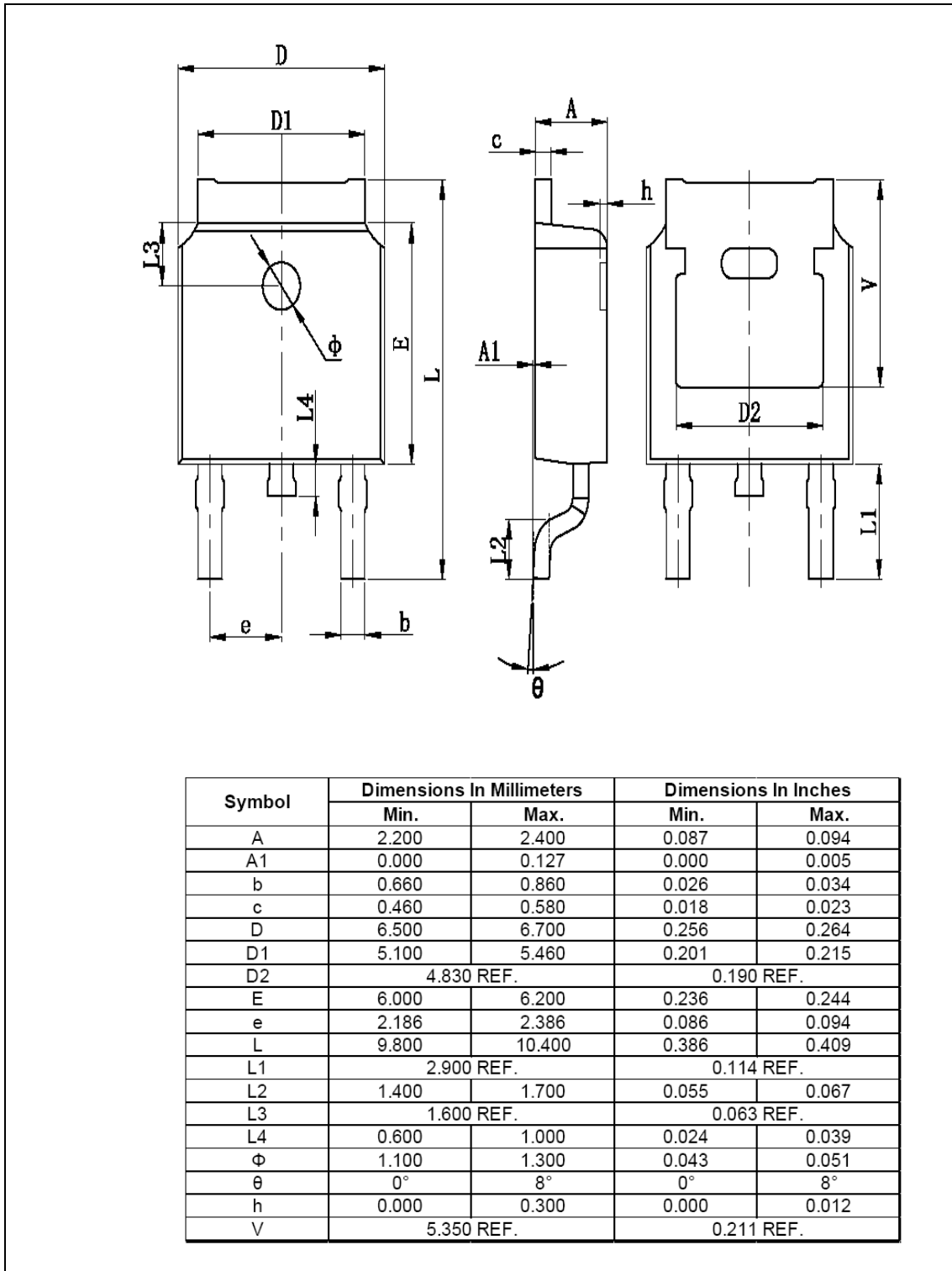

■ Package Information

Figure3, TO220F package outline dimension

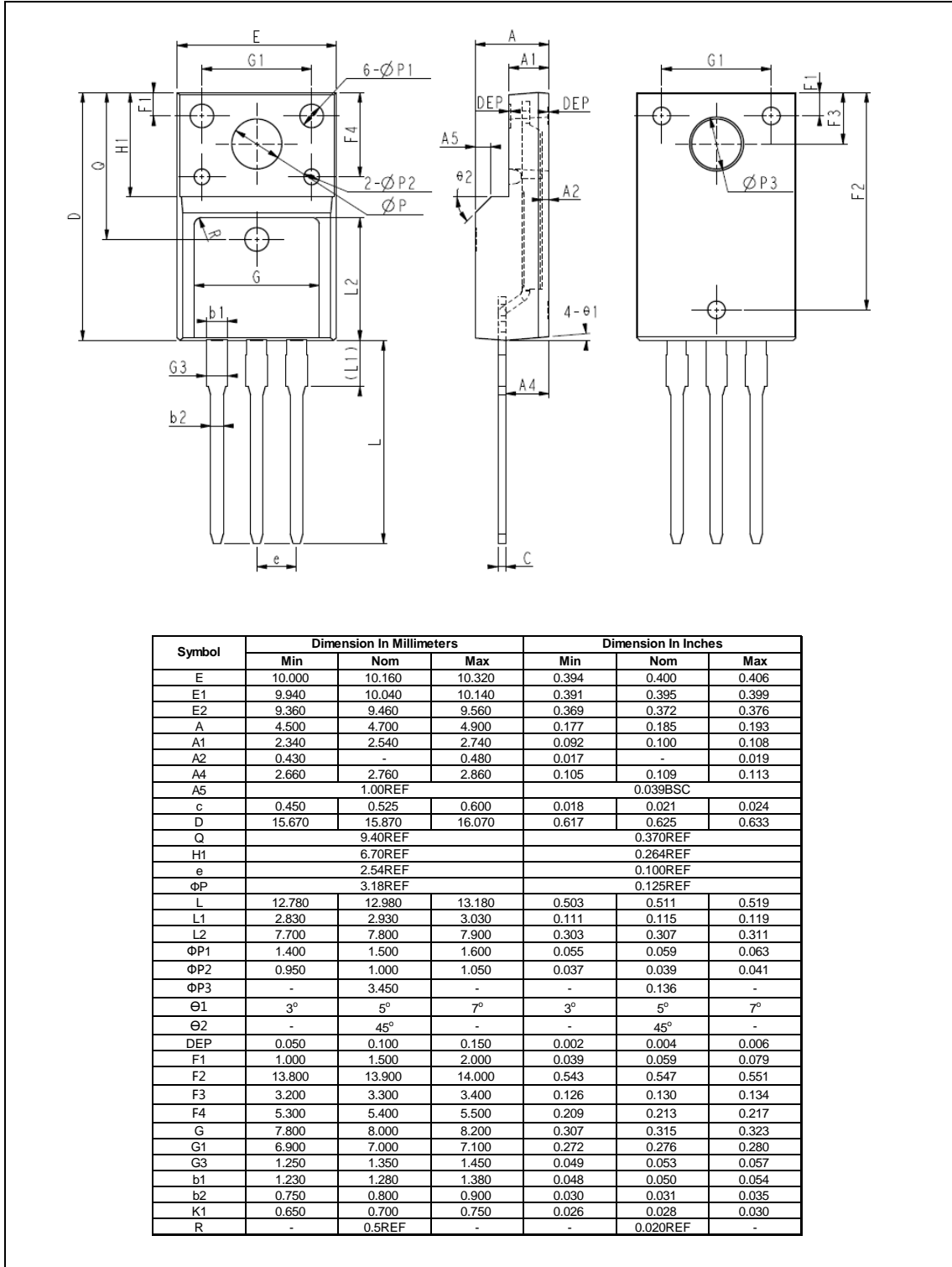

■ Package Information

Figure4, TO220 package outline dimension

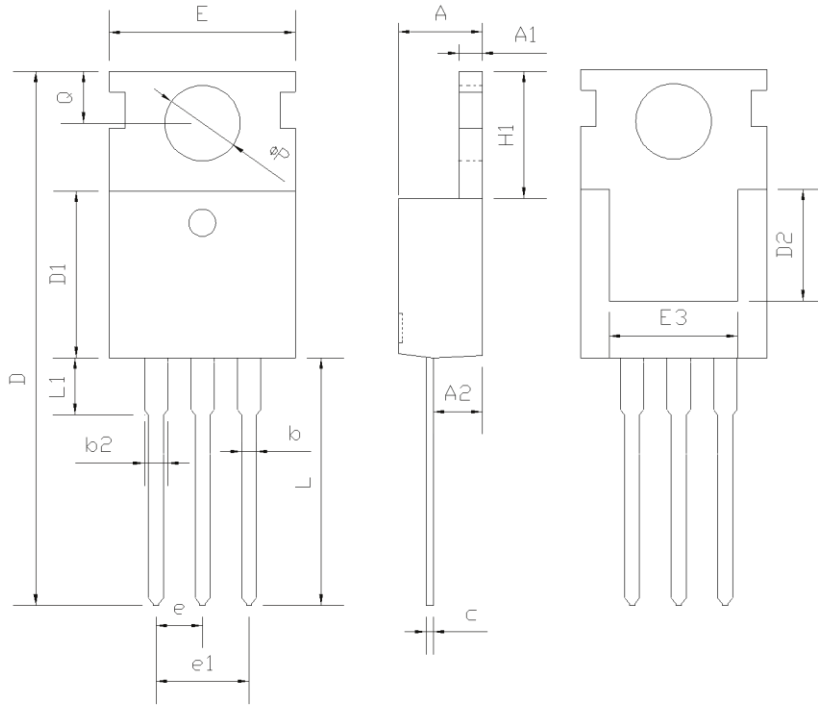

Symbol	Min	Nom	Max
A	4.37	4.57	4.77
A1	1.25	1.30	1.45
A2	2.20	2.40	2.60
b	0.70	0.80	0.95
b2	1.17	1.27	1.47
c	0.40	0.50	0.65
D	15.10	15.60	16.10
D1	8.80	9.10	9.40
D2	5.50	-	-
E	9.70	10.00	10.30
E3	7.00	-	-
e	2.54 BSC		
e1	5.08 BSC		
H1	6.25	6.50	6.85
L	12.75	13.50	13.80
L1	-	3.10	3.40
ΦP	3.40	3.60	3.80
Q	2.60	2.80	3.00

■ Ordering Information

Package	Units/Tube	Tubes/Inner Box	Units/Inner Box	Inner Box/Carton Box	Units/Carton Box
TO251	75	66	4950	6	29700
TO252 Option1	75	66	4950	6	29700
TO220F	50	20	1000	6	6000
TO220	50	20	1000	6	6000

Package	Units/Tape	Tapes/Inner Box	Units/Inner Box	Inner Box/Carton Box	Units/Carton Box
TO252 Option2	2500	2	5000	5	25000

■ Product Information

Product	Package	Pb Free	RoHS	Halogen Free
OSG65R290A	TO251	yes	yes	no
OSG65R290AF	TO251	yes	yes	yes
OSG65R290D	TO252	yes	yes	no
OSG65R290DF	TO252	yes	yes	yes
OSG65R290F	TO220F	yes	yes	no
OSG65R290FF	TO220F	yes	yes	yes
OSG65R290P	TO220	yes	yes	no
OSG65R290PF	TO220	yes	yes	yes