

Enhancement Mode N-Channel Power MOSFET

Features

- ◆ Low $R_{DS(on)}$ & FOM
- ◆ Extremely low switching loss
- ◆ Excellent stability and uniformity
- ◆ Easy to drive

Applications



- ◆ Lighting
- ◆ Hard switching PWM
- ◆ Server power supply
- ◆ Charger

■ General Description

OSG65R900xTF use advanced GreenMOS™ technology to provide low $R_{DS(ON)}$, low gate charge, fast switching and excellent avalanche characteristics. This device is suitable for active power factor correction and switching mode power supply applications.

◆ $V_{DS, min@Tjmax}$	700 V
◆ $I_{D, pulse}$	13.5 A
◆ $R_{DS(ON), max @ V_{GS}=10 V}$	900 mΩ
◆ Q_g	7.1 nC

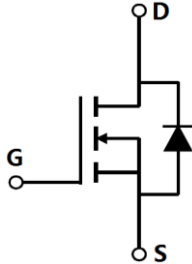
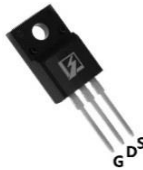
■ Schematic and Package Information

Schematic Diagram	Pin Assignment Top View
	 <p>TO220F OSG65R900FTF</p>  <p>TO252 OSG65R900DTF</p>

■ Absolute Maximum Ratings at $T_j=25^\circ\text{C}$ unless otherwise noted

Parameter	Symbol	Value	Unit
Drain source voltage	V_{DS}	650	V
Gate source voltage	V_{GS}	±30	V
Continuous drain current ¹⁾ , $T_C=25^\circ\text{C}$	I_D	4.5	A
Continuous drain current ¹⁾ , $T_C=100^\circ\text{C}$		2.8	
Pulsed drain current ²⁾ , $T_C=25^\circ\text{C}$	$I_{D, pulse}$	13.5	A
Power dissipation ³⁾ for TO252, $T_C=25^\circ\text{C}$	P_D	32	W
Power dissipation ³⁾ for TO220F, $T_C=25^\circ\text{C}$		25	
Single pulsed avalanche energy ⁵⁾	E_{AS}	50	mJ
MOSFET dv/dt ruggedness, $V_{DS}=0\dots480\text{ V}$	dv/dt	50	V/ns
Reverse diode dv/dt, $V_{DS}=0\dots480\text{ V}$, $I_{SD}\leq I_D$	dv/dt	15	V/ns
Operation and storage temperature	T_{stg}, T_j	-55 to 150	°C

■ Thermal Characteristics

Parameter	Symbol	Value		Unit
		TO252	TO220F	
Thermal resistance, junction-case	$R_{\theta JC}$	3.9	5.0	°C/W
Thermal resistance, junction-ambient ⁴⁾	$R_{\theta JA}$	62	62.5	°C/W

■ Electrical Characteristics at $T_j=25\text{ }^\circ\text{C}$ unless otherwise specified

Parameter	Symbol	Min.	Typ.	Max.	Unit	Test condition
Drain-source breakdown voltage	BV_{DSS}	650			V	$V_{GS}=0\text{ V}$, $I_D=250\text{ }\mu\text{A}$
		700				$V_{GS}=0\text{ V}$, $I_D=250\text{ }\mu\text{A}$ $T_j=150\text{ }^\circ\text{C}$
Gate threshold voltage	$V_{GS(th)}$	2.9		3.9	V	$V_{DS}=V_{GS}$, $I_D=250\text{ }\mu\text{A}$
Drain-source on-state resistance	$R_{DS(on)}$		0.75	0.9	Ω	$V_{GS}=10\text{ V}$, $I_D=2\text{ A}$
			1.75			$V_{GS}=10\text{ V}$, $I_D=2\text{ A}$, $T_j=150\text{ }^\circ\text{C}$
Gate-source leakage current	I_{GSS}			100	nA	$V_{GS}=30\text{ V}$
				-100		$V_{GS}=-30\text{ V}$
Drain-source leakage current	I_{DSS}			1	μA	$V_{DS}=650\text{ V}$, $V_{GS}=0\text{ V}$

■ Dynamic Characteristics

Parameter	Symbol	Min.	Typ.	Max.	Unit	Test condition
Input capacitance	C_{iss}		324.1		pF	$V_{GS}=0\text{ V}$, $V_{DS}=50\text{ V}$, $f=100\text{ kHz}$
Output capacitance	C_{oss}		30.1		pF	
Reverse transfer capacitance	C_{rss}		1.6		pF	
Turn-on delay time	$t_{d(on)}$		22.8		ns	$V_{GS}=10\text{ V}$, $V_{DS}=400\text{ V}$, $R_G=2\text{ }\Omega$, $I_D=2\text{ A}$
Rise time	t_r		11.5		ns	
Turn-off delay time	$t_{d(off)}$		48.7		ns	
Fall time	t_f		14.9		ns	

■ Gate Charge Characteristics

Parameter	Symbol	Min.	Typ.	Max.	Unit	Test condition
Total gate charge	Q_g		7.1		nC	$I_D=2\text{ A}$, $V_{DS}=400\text{ V}$, $V_{GS}=10\text{ V}$
Gate-source charge	Q_{gs}		1.5		nC	
Gate-drain charge	Q_{gd}		3.5		nC	
Gate plateau voltage	V_{plateau}		5.8		V	

■ Body Diode Characteristics

Parameter	Symbol	Min.	Typ.	Max.	Unit	Test condition
Diode forward current	I_S			4.5	A	$V_{GS} < V_{th}$
Pulsed source current	I_{SP}			13.5		
Diode forward voltage	V_{SD}			1.3	V	$I_S=4.5\text{ A}$, $V_{GS}=0\text{ V}$
Reverse recovery time	t_{rr}		147.0		ns	$V_R=400\text{ V}$, $I_S=2\text{ A}$, $di/dt=100\text{ A}/\mu\text{s}$
Reverse recovery charge	Q_{rr}		0.92		μC	
Peak reverse recovery current	I_{rrm}		12.4		A	

■ Note

- 1) Calculated continuous current based on maximum allowable junction temperature.
- 2) Repetitive rating; pulse width limited by max. junction temperature.
- 3) P_d is based on max. junction temperature, using junction-case thermal resistance.
- 4) The value of $R_{\theta JA}$ is measured with the device mounted on 1 in 2 FR-4 board with 2oz. Copper, in a still air environment with $T_a=25\text{ }^\circ\text{C}$.
- 5) $V_{DD}=100\text{ V}$, $R_G=50\text{ }\Omega$, $L=60\text{ mH}$, starting $T_j=25\text{ }^\circ\text{C}$.

■ **Electrical Characteristics Diagrams**

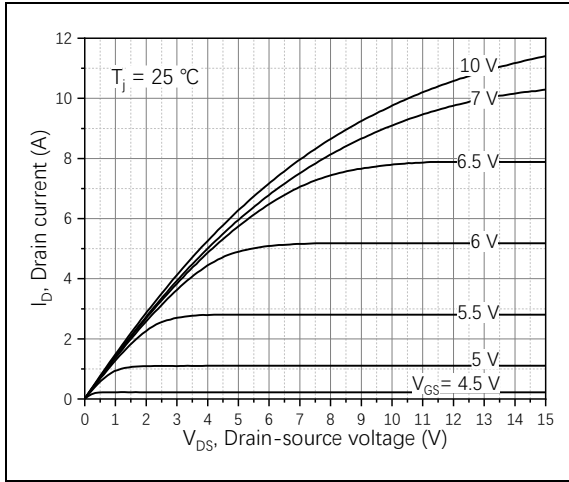

Figure 1, Typ. output characteristics

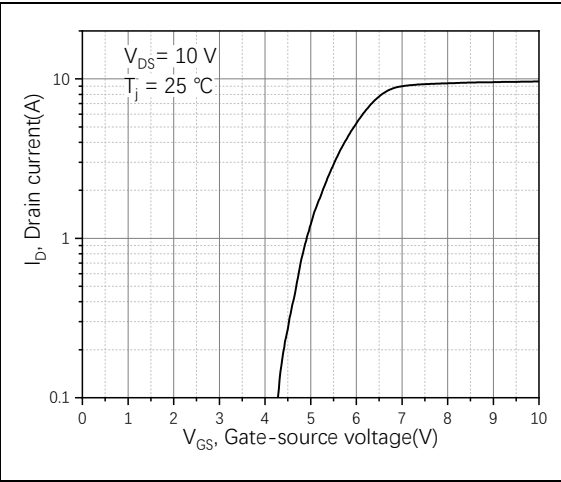

Figure 2, Typ. transfer characteristics

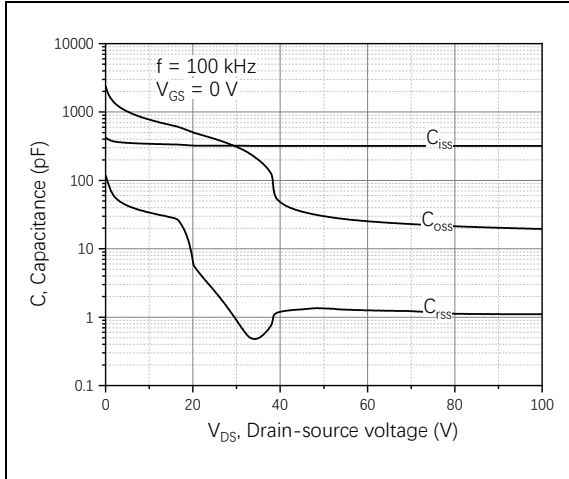

Figure 3, Typ. capacitances

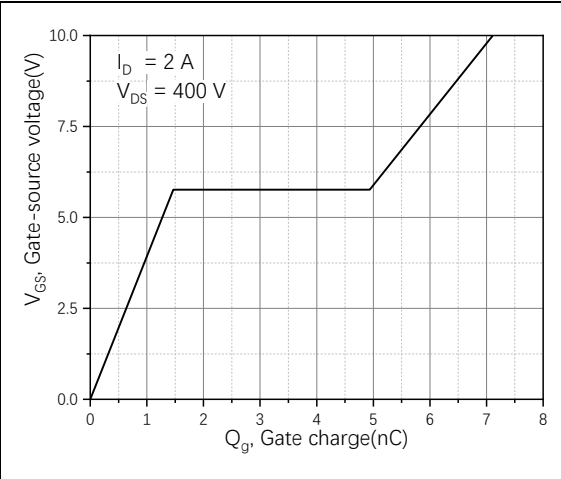

Figure 4, Typ. gate charge

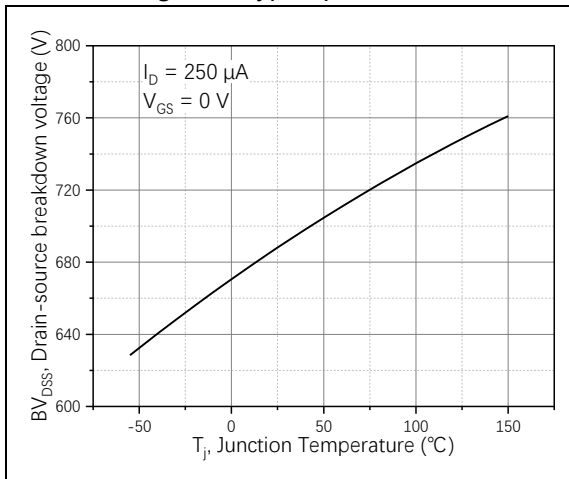

Figure 5, Drain-source breakdown voltage

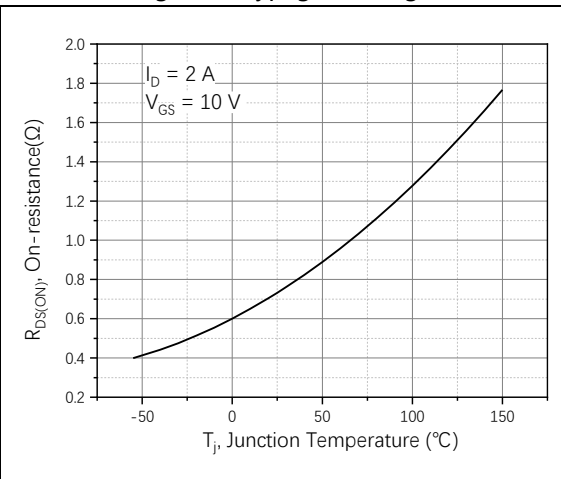

Figure 6, Drain-source on-state resistance

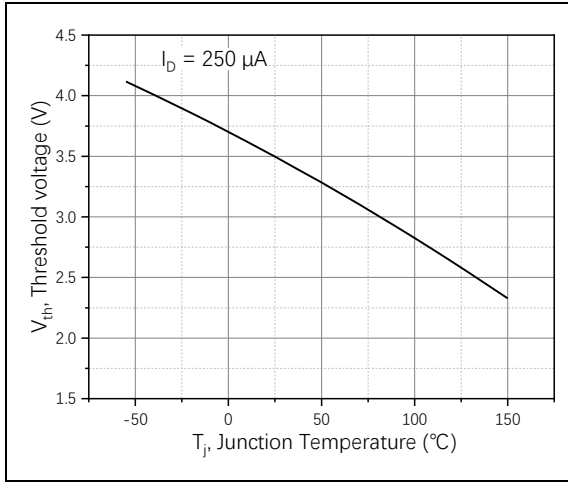

Figure 7, Threshold voltage

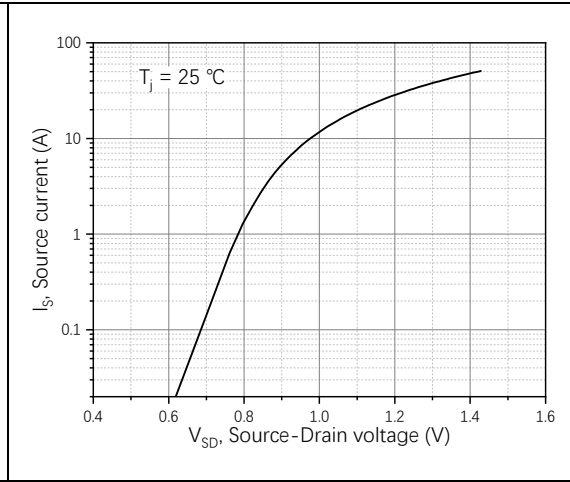

Figure 8, Forward characteristic of body diode

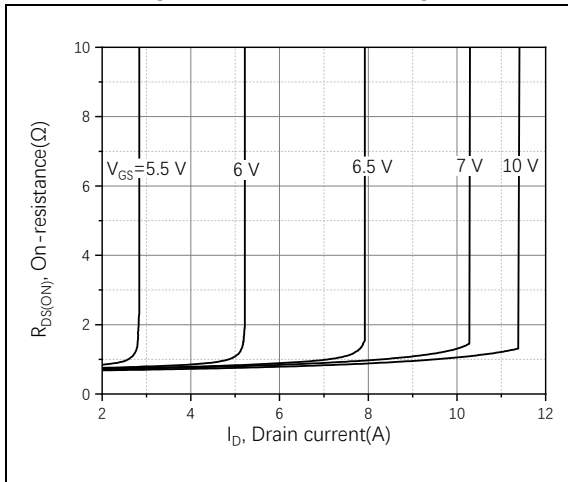

Figure 9, Drain-source on-state resistance

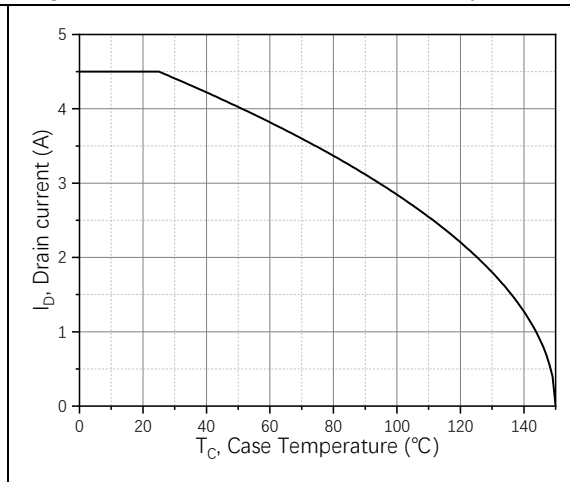

Figure 10, Drain current

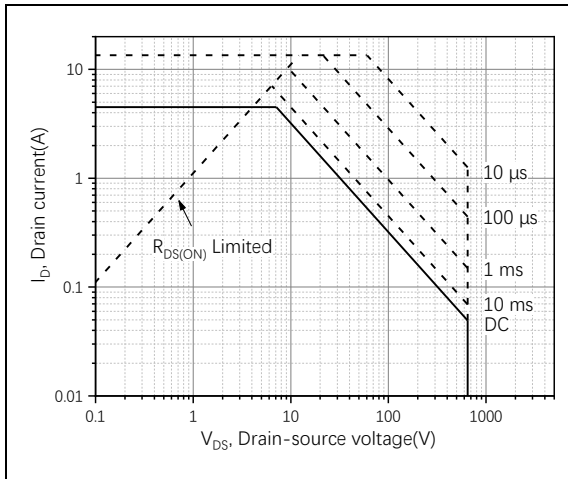

Figure 11, Safe operation area for TO252
 $T_C = 25\text{ }^\circ\text{C}$

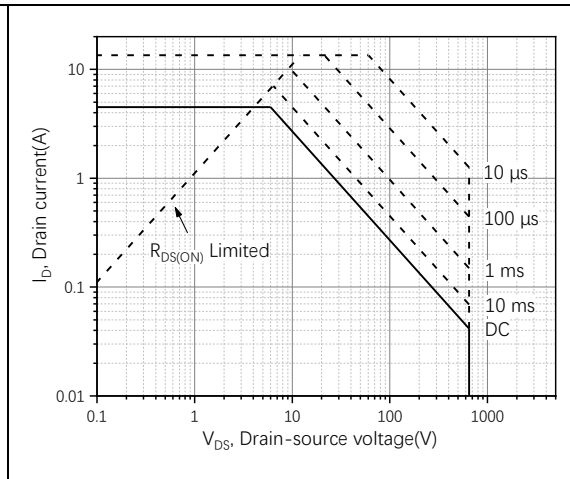

Figure 12, Safe operation area for TO220F
 $T_C = 25\text{ }^\circ\text{C}$

■ Test circuits and waveforms

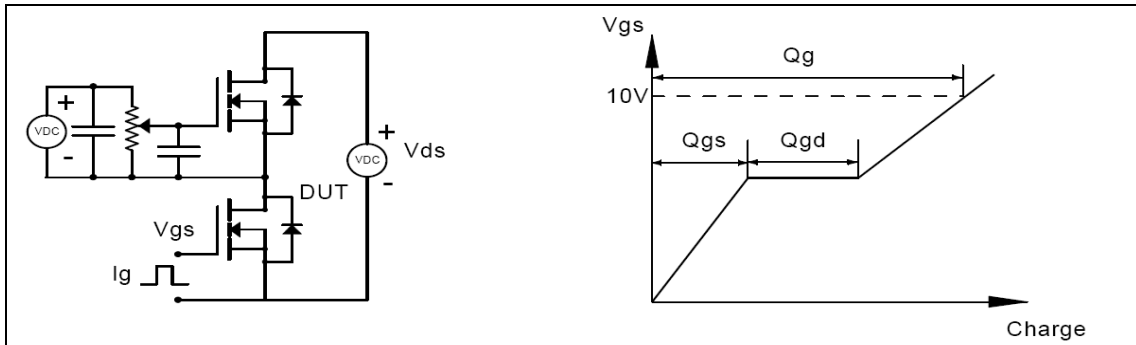

Figure 1, Gate charge test circuit & waveform

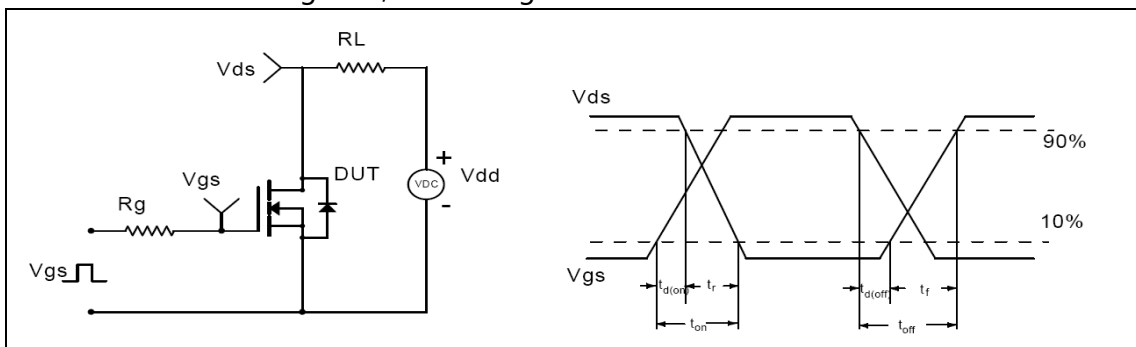

Figure 2, Switching time test circuit & waveforms

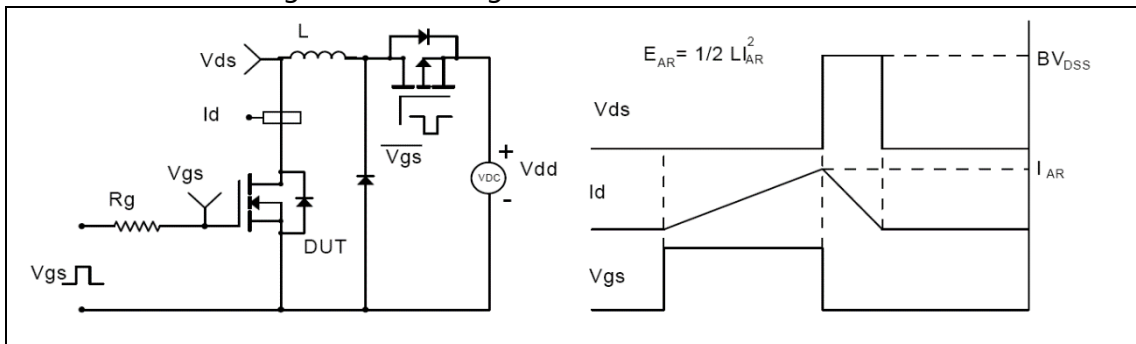

Figure 3, Unclamped inductive switching (UIS) test circuit & waveforms

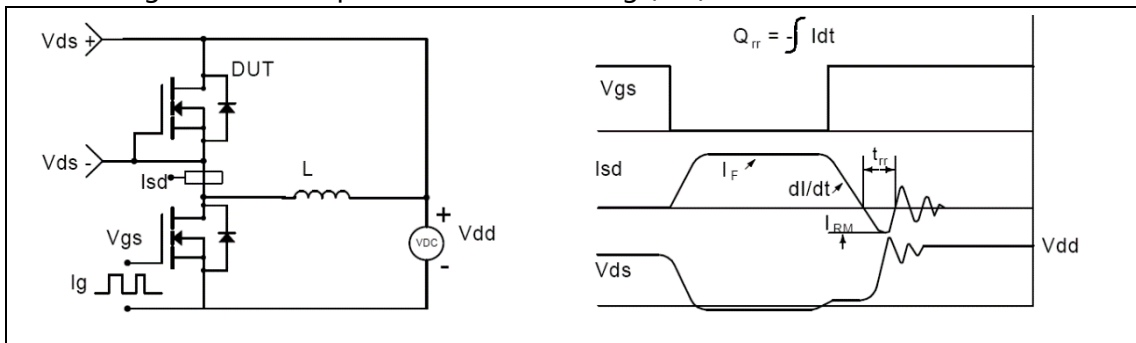
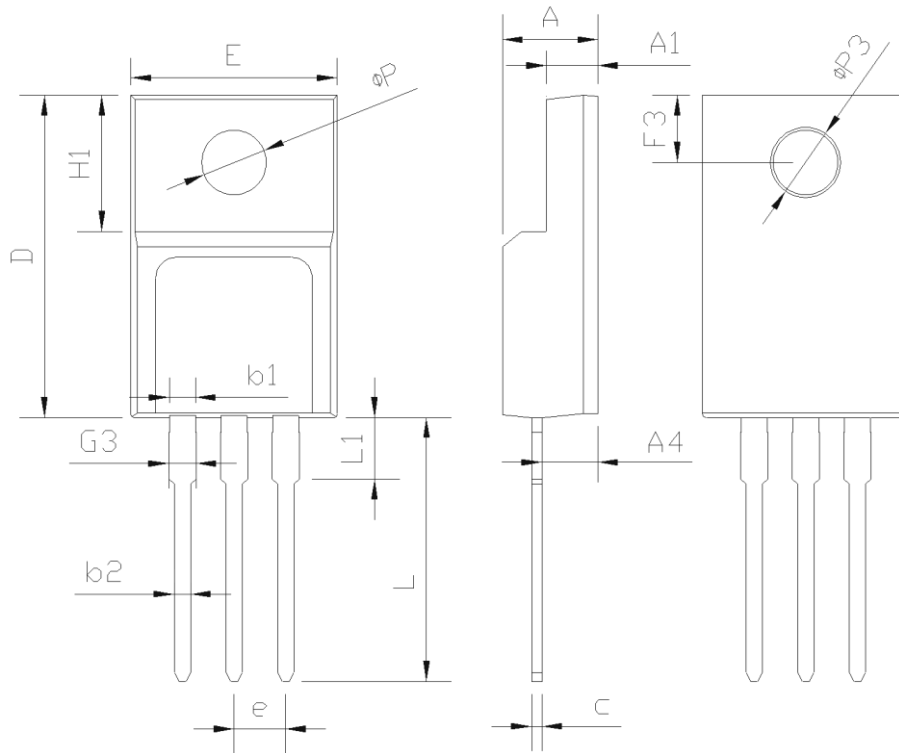

Figure 4, Diode reverse recovery test circuit & waveforms

■ Package Information

Figure1, TO220F package outline dimension



SYMBOL	mm		
	MIN	NOM	MAX
E	9.96	10.16	10.36
A	4.50	4.70	4.90
A1	2.34	2.54	2.74
A4	2.56	2.76	2.96
c	0.40	0.50	0.65
D	15.57	15.87	16.17
H1	6.70REF		
e	2.54BSC		
L	12.68	12.98	13.28
L1	2.88	3.03	3.18
ΦP	3.03	3.18	3.38
ΦP3	3.15	3.45	3.65
F3	3.15	3.30	3.45
G3	1.25	1.35	1.55
b1	1.18	1.28	1.43
b2	0.70	0.80	0.95

■ Package Information

Figure2, TO252 package outline dimension

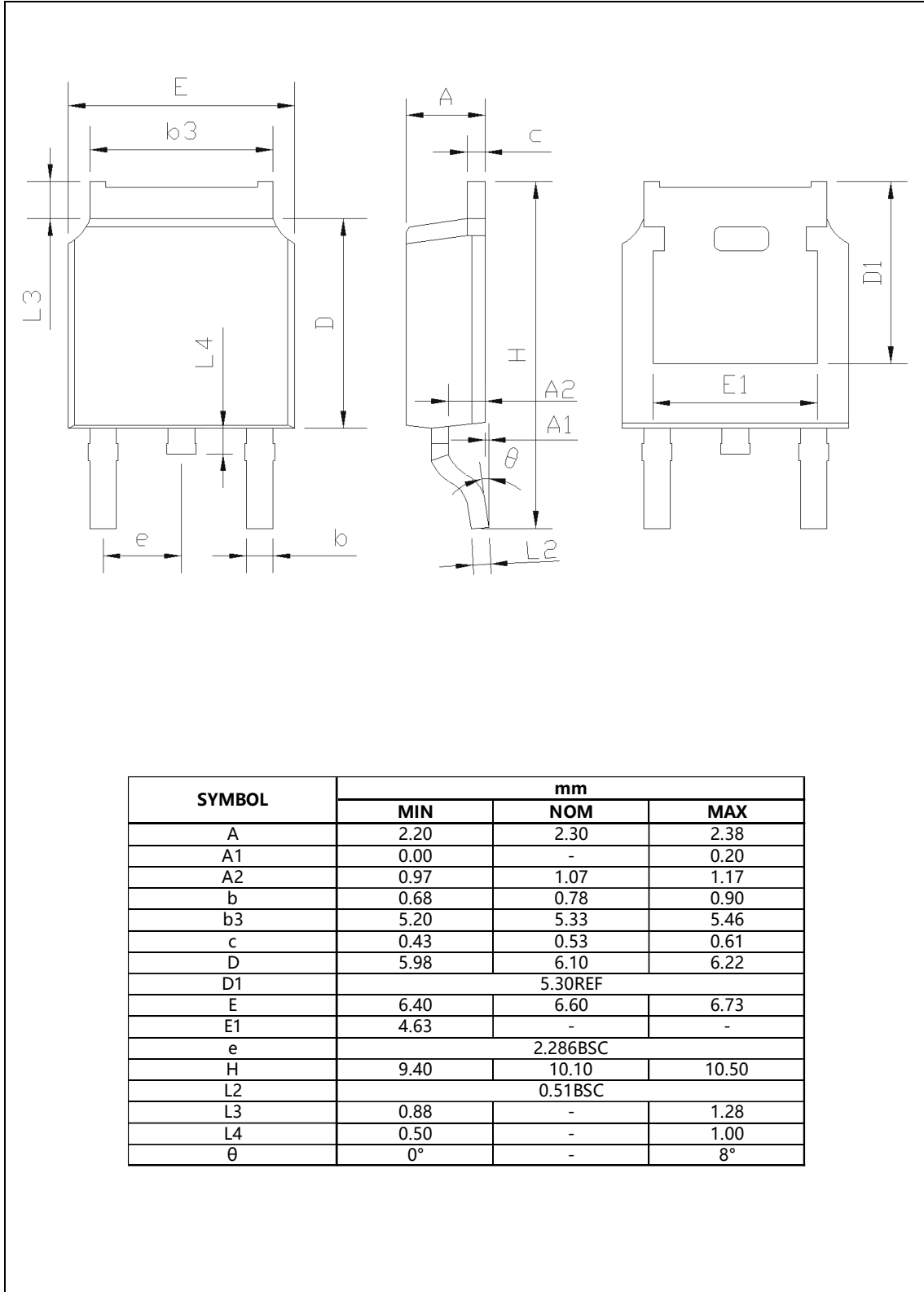

■ Ordering Information

Package	Units/Tube	Tubes/Inner Box	Units/Inner Box	Inner Box/Carton Box	Units/Carton Box
TO220F	50	20	1000	6	6000

Package	Units/Reel	Reels/Inner Box	Units/Inner Box	Inner Box/Carton Box	Units/Carton Box
TO252	2500	2	5000	5	25000

■ Product Information

Product	Package	Pb Free	RoHS	Halogen Free
OSG65R900FTF	TO220F	yes	yes	yes
OSG65R900DTF	TO252	yes	yes	yes