

# Enhancement Mode N-Channel Power MOSFET

## Features

- ◆ Low  $R_{DS(on)}$  & FOM
- ◆ Extremely low switching loss
- ◆ Excellent stability and uniformity
- ◆ Fast switching and soft recovery

## Applications

- ◆ Consumer electronic power supply
- ◆ Motor control
- ◆ Synchronous rectification
- ◆ Isolated DC/DC convertor
- ◆ Invertors

## ■ General Description

SFG10S20DF uses advanced SFGMOS™ technology to provide low  $R_{DS(ON)}$ , low gate charge, fast switching and excellent avalanche characteristics. This device is specially designed to get better ruggedness and suitable to use in synchronous rectification applications.

◆ $V_{DS, min}$	100 V
◆ $I_{D, pulse}$	48 A
◆ $R_{DS(ON), max @ V_{GS}=10 V}$	14 mΩ
◆ $Q_g$	16.2 nC

## ■ Schematic and Package Information

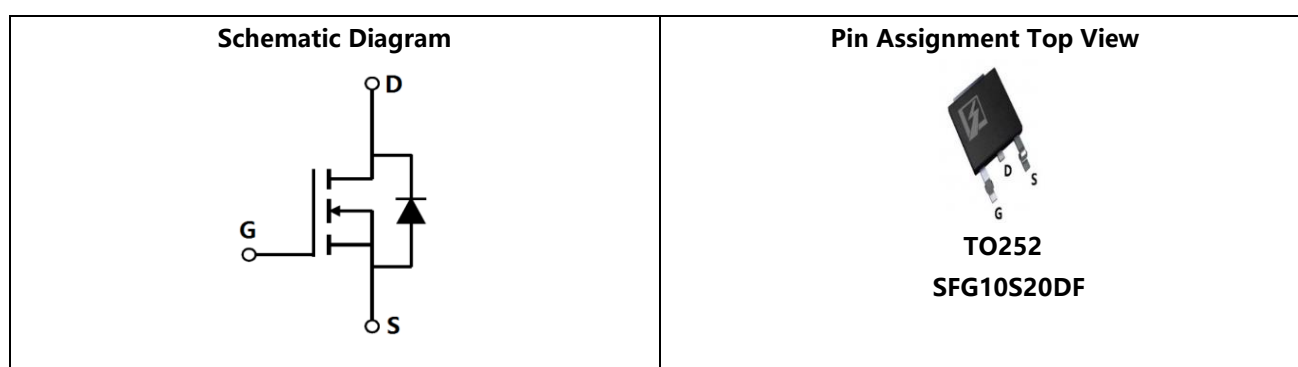

## ■ Absolute Maximum Ratings at $T_j=25^\circ\text{C}$ unless otherwise noted

Parameter	Symbol	Value	Unit
Drain source voltage	$V_{DS}$	100	V
Gate source voltage	$V_{GS}$	$\pm 20$	V
Continuous drain current <sup>1)</sup> , $T_C=25^\circ\text{C}$	$I_D$	16	A
Pulsed drain current <sup>2)</sup> , $T_C=25^\circ\text{C}$	$I_{D, pulse}$	48	A
Power dissipation <sup>3)</sup> , $T_C=25^\circ\text{C}$	$P_D$	50	W
Single pulsed avalanche energy <sup>5)</sup>	$E_{AS}$	57	mJ
Operation and storage temperature	$T_{stg}, T_j$	-55 to 150	$^\circ\text{C}$

## ■ Thermal Characteristics

Parameter	Symbol	Value	Unit
Thermal resistance, junction-case	$R_{\theta JC}$	2.5	$^{\circ}\text{C}/\text{W}$
Thermal resistance, junction-ambient <sup>4)</sup>	$R_{\theta JA}$	62	$^{\circ}\text{C}/\text{W}$

## ■ Electrical Characteristics at $T_j=25^{\circ}\text{C}$ unless otherwise specified

Parameter	Symbol	Min.	Typ.	Max.	Unit	Test condition
Drain-source breakdown voltage	$BV_{DSS}$	100			V	$V_{GS}=0\text{ V}, I_D=250\ \mu\text{A}$
Gate threshold voltage	$V_{GS(th)}$	1.4		2.5	V	$V_{DS}=V_{GS}, I_D=250\ \mu\text{A}$
Drain-source on-state resistance	$R_{DS(on)}$		13.8	20.0	$\text{m}\Omega$	$V_{GS}=10\text{ V}, I_D=10\text{ A}$
Drain-source on-state resistance	$R_{DS(on)}$		17.4	26.0	$\text{m}\Omega$	$V_{GS}=4.5\text{ V}, I_D=7\text{ A}$
Gate-source leakage current	$I_{GSS}$			100	nA	$V_{GS}=20\text{ V}$
				-100		$V_{GS}=-20\text{ V}$
Drain-source leakage current	$I_{DSS}$			1	$\mu\text{A}$	$V_{DS}=80\text{ V}, V_{GS}=0\text{ V}$

## ■ Dynamic Characteristics

Parameter	Symbol	Min.	Typ.	Max.	Unit	Test condition
Input capacitance	$C_{iss}$		1003.9		pF	$V_{GS}=0\text{ V},$ $V_{DS}=50\text{ V},$ $f=100\text{ kHz}$
Output capacitance	$C_{oss}$		185.4		pF	
Reverse transfer capacitance	$C_{rss}$		9.8		pF	
Turn-on delay time	$t_{d(on)}$		16.6		ns	$V_{GS}=10\text{ V},$ $V_{DS}=50\text{ V},$ $R_G=10\ \Omega,$ $I_D=5\text{ A}$
Rise time	$t_r$		3.8		ns	
Turn-off delay time	$t_{d(off)}$		75.5		ns	
Fall time	$t_f$		46		ns	

## ■ Gate Charge Characteristics

Parameter	Symbol	Min.	Typ.	Max.	Unit	Test condition
Total gate charge	$Q_g$		16.2		nC	$I_D=5\text{ A}$ , $V_{DS}=50\text{ V}$ , $V_{GS}=10\text{ V}$
Gate-source charge	$Q_{gs}$		2.8		nC	
Gate-drain charge	$Q_{gd}$		4.1		nC	
Gate plateau voltage	$V_{\text{plateau}}$		3		V	

## ■ Body Diode Characteristics

Parameter	Symbol	Min.	Typ.	Max.	Unit	Test condition
Diode forward current	$I_S$			16	A	$V_{GS}<V_{th}$
Pulsed source current	$I_{SP}$			48		
Diode forward voltage	$V_{SD}$			1.3	V	$I_S=12\text{ A}$ , $V_{GS}=0\text{ V}$
Reverse recovery time	$t_{rr}$		49		ns	$I_S=5\text{ A}$ , $di/dt=100\text{ A}/\mu\text{s}$
Reverse recovery charge	$Q_{rr}$		61.8		nC	
Peak reverse recovery current	$I_{rrm}$		2.4		A	

## ■ Note

- 1) Calculated continuous current based on maximum allowable junction temperature.
- 2) Repetitive rating; pulse width limited by max. junction temperature.
- 3)  $P_d$  is based on max. junction temperature, using junction-case thermal resistance.
- 4) The value of  $R_{\theta JA}$  is measured with the device mounted on 1 in 2 FR-4 board with 2oz. Copper, in a still air environment with  $T_a=25\text{ }^\circ\text{C}$ .
- 5)  $V_{DD}=50\text{ V}$ ,  $R_G=50\text{ }\Omega$ ,  $L=0.3\text{ mH}$ , starting  $T_j=25\text{ }^\circ\text{C}$ .

■ **Electrical Characteristics Diagrams**

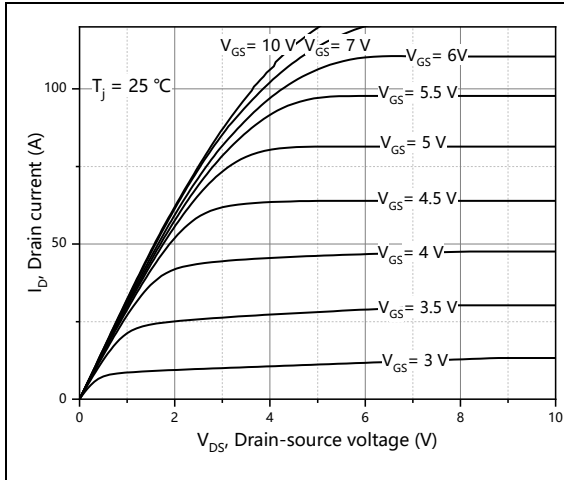

Figure 1, Typ. output characteristics

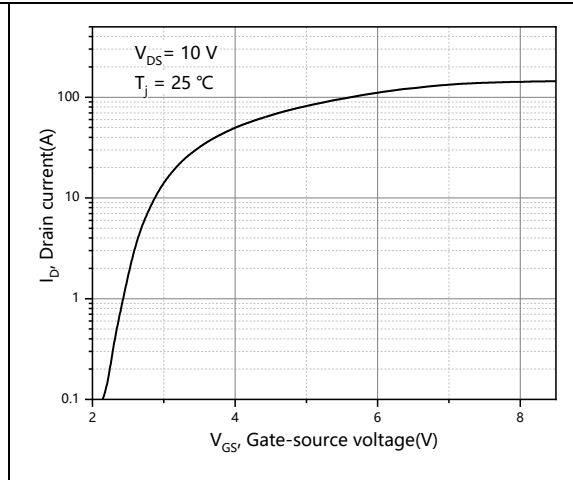

Figure 2, Typ. transfer characteristics

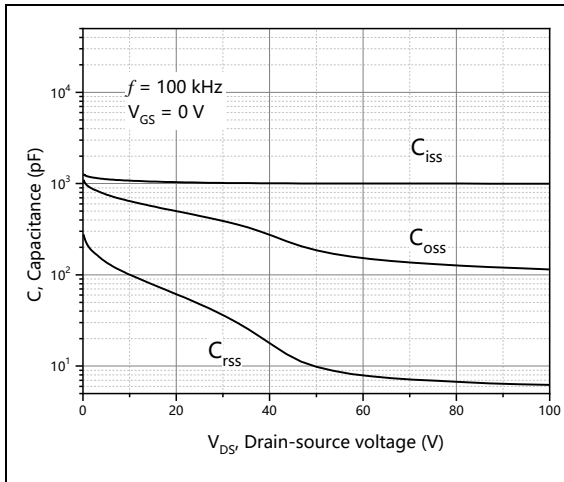

Figure 3, Typ. capacitances

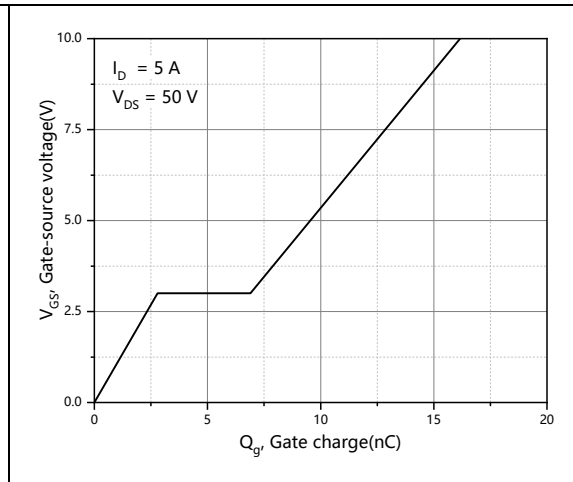

Figure 4, Typ. gate charge

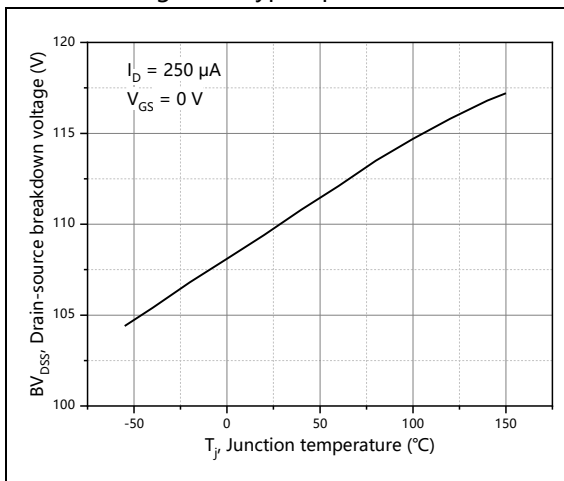

Figure 5, Drain-source breakdown voltage

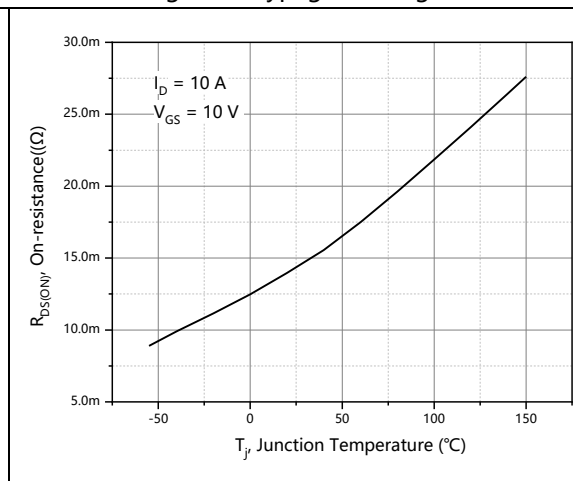

Figure 6, Drain-source on-state resistance

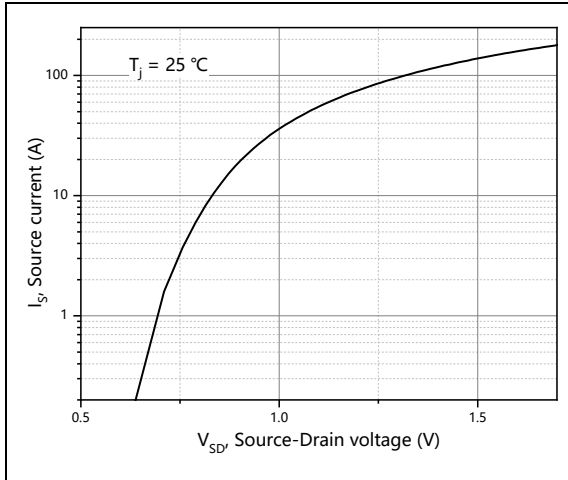

Figure 7, Forward characteristic of body diode

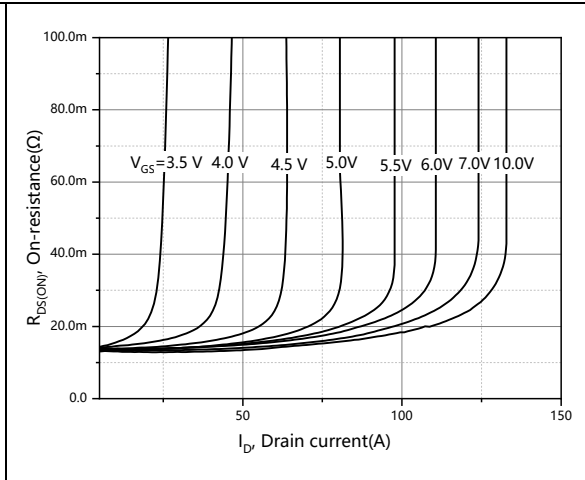

Figure 8, Drain-source on-state resistance

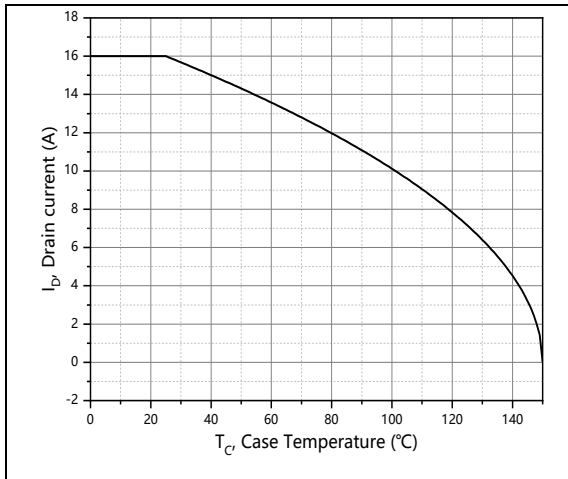

Figure 9, Drain current

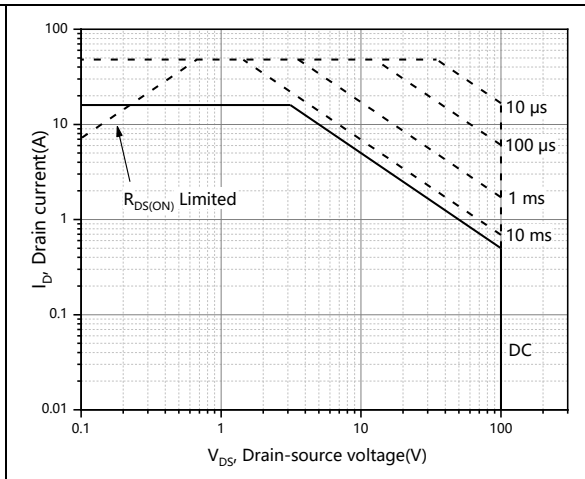

Figure 10, Safe operation area  $T_C=25\text{ }^\circ\text{C}$

■ Test circuits and waveforms

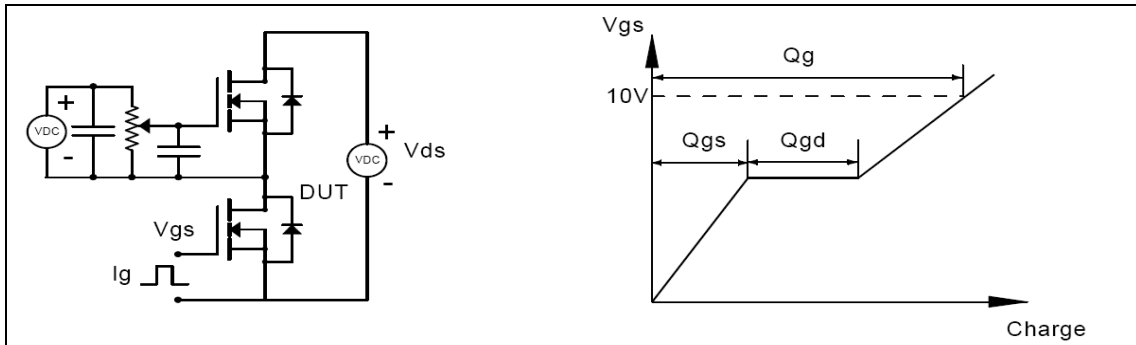

Figure 1, Gate charge test circuit & waveform

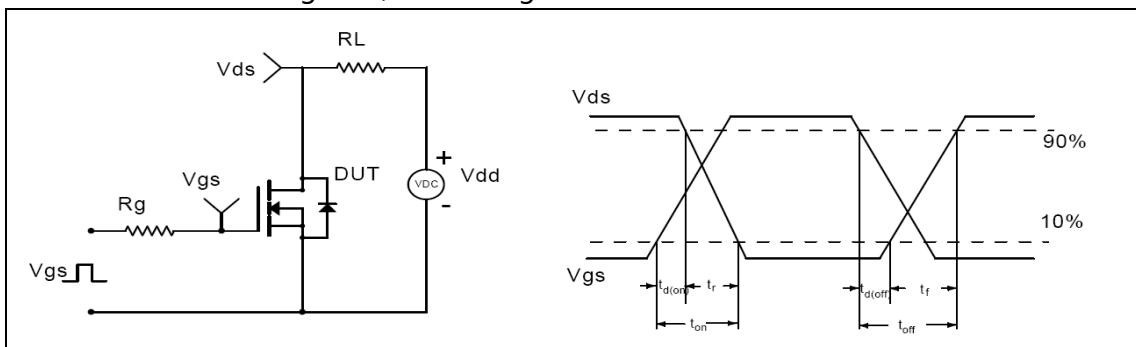

Figure 2, Switching time test circuit & waveforms

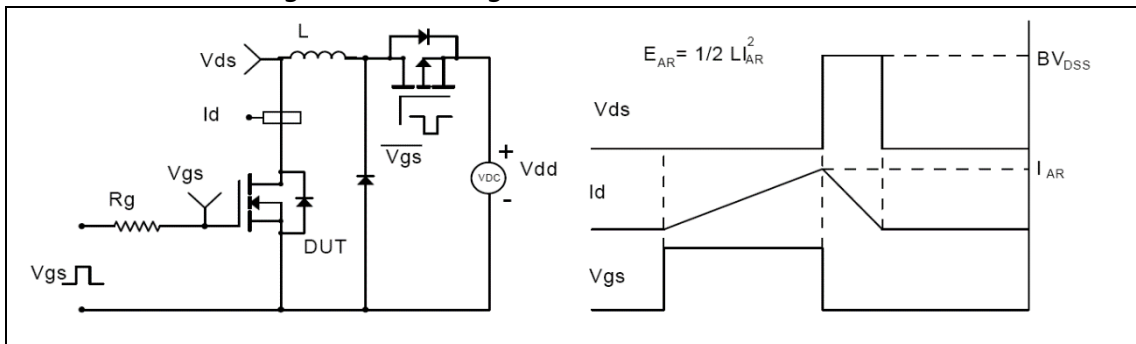

Figure 3, Unclamped inductive switching (UIS) test circuit & waveforms

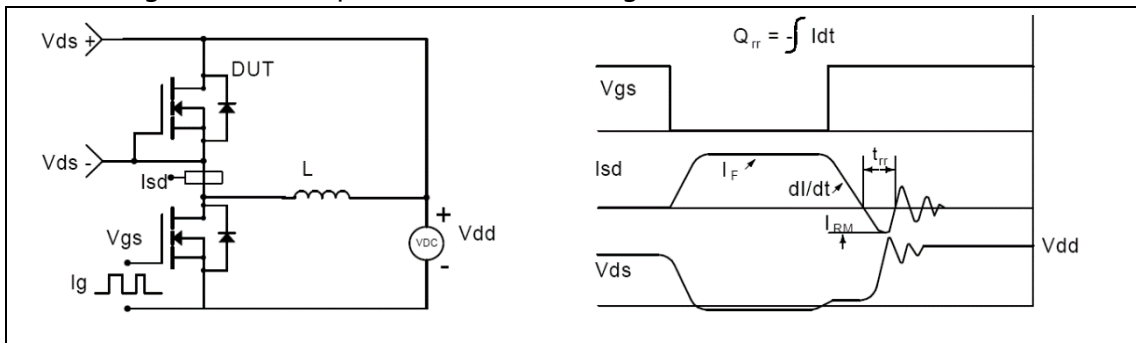
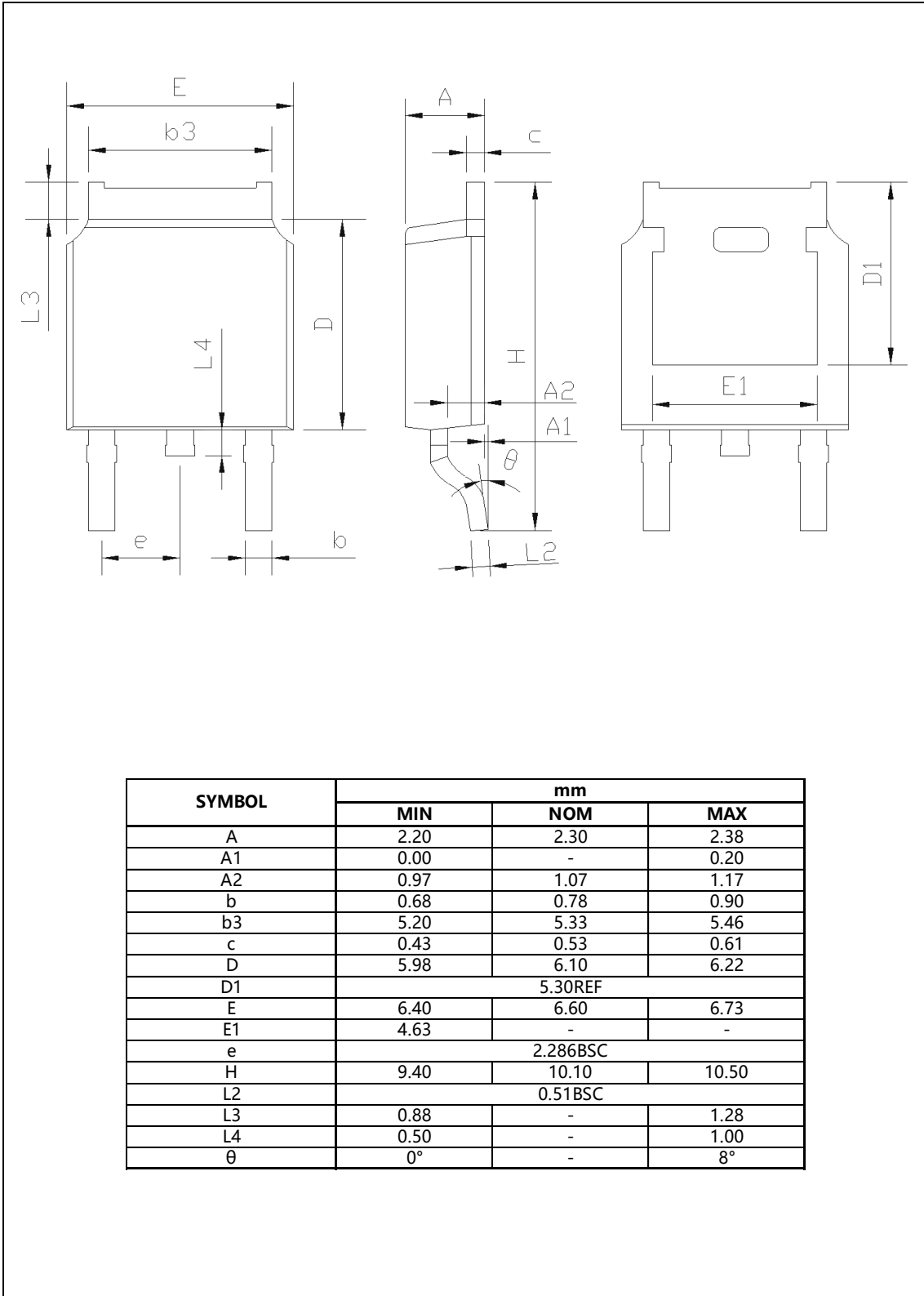

Figure 4, Diode reverse recovery test circuit & waveforms

■ Package Information

Figure1, Figure1, TO252 package outline dimension





---

**■ Ordering Information**

---

Package	Units/Reel	Reels/Inner Box	Units/Inner Box	Inner Box/Carton Box	Units/Carton Box
TO252	2500	2	5000	5	25000

---

**■ Product Information**

---

Product	Package	Pb Free	RoHS	Halogen Free
SFG10S20DF	TO252	yes	yes	yes